

# Hyperspectral Camera

Hyperspectral camera equipped with Sony's IMX992

## Hyperspectral imaging camera AHS-052VIR

Equipped with Sony's proprietary "IMX992" sensor, this high-definition industrial hyperspectral camera is built with the industry's highest resolution\* image sensor.

With a 2560-pixel line sensor, it performs spectral separation across a broad range from the visible light region (450nm) to the short-wave infrared region (1700nm), capturing complete spectral data in 1680 wavelength bands.

\* According to Sony's research (as of November 2023), this resolution is the highest in the industry among industrial SWIR image sensors made using the compound semiconductor InGaAs (Indium Gallium Arsenide).



### ■ AHS-052VIR Specification

Model	AHS-052VIR-GE	
Image sensor	Effective pixel : 2560H (Spatial)×1680V (Spectral) Pixel size : 3.45μm×3.45μm InGaAs sensor, 1-stage electronic cooling	
Interface	10Gigabit Ethernet (10GBASE-T)	
Sensitivity wavelength	450nm~1700nm	
Number of detection bands	1680bands	
Wavelength resolution	4.66nm ※Theoretical value	
Imaging method	Push-broom method (line scan method)	
Frame rate	8bit 145.99FPS (max) 10bit 104.63FPS (max) 12bit 85.68FPS (max)	
Exposure time	8bit	8μsec~10msec (Adjustable range : 8μsec~9.99sec)
	10bit	8μsec~10msec (Adjustable range : 8μsec~9.99sec)
	12bit	13μsec~10msec (Adjustable range : 13μsec~9.99sec)
Pixel clock cycle	74.25MHz	
S/N	47dB	
Gain	0dB~+12dB (Configurable range : 0dB~30dB)	
Black level	Adjustable from 0 LSB to 127 LSB (in 10 bit mode)	
Main functions	Status LED, internal cooling mechanism, external trigger, various corrections (DSNU, PRNU, pixel defects, shading), ROI, field upgrade function, wavelength selection, binning	
Image output	8 / 10 / 12bit	
Lens mount	C-mount 2/3 inch	
Peltier set temperature	-30°C~+60°C set to 15°C at shipment (However, it should be used within the operating temperature range)	
Operating temp / humidity	+0°C~+45°C 20~80% (non-condensing)	
Storage temp / humidity	-15°C~+65°C 20~80% (non-condensing)	
Power	Input voltage range : DC +12V to +24V ±1V Power consumption : 13W (typ) ※When using external power DC +24V	
Dimensions	92(W) x 92(H) x 241(D) mm (Excluding mount and protruding parts)	
Weight	2.0kg (typ.)	
Compliance	RoHS2	
Standard	GigE Vision®, GenICam™, GenICam™ GenTL	
Camera update tool	SightCam	
Cable (video output)	LAN cable compatible with CAT6A and CAT7 (optional)	
SDK	For imaging / communication : SDK-AcapLib2 (Model : AZP-ACAP-02) Hysight : Viewer for hyperspectral cameras	

### External dimensions

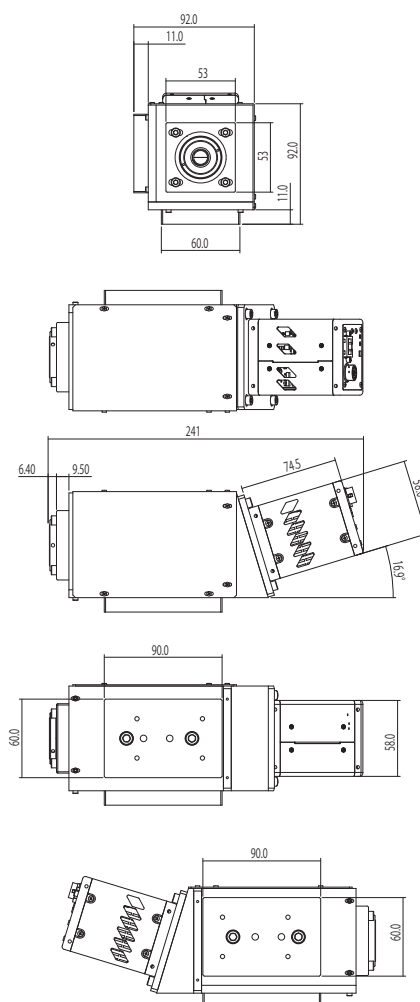

### Viewer for hyperspectral cameras



Spectral image HySight Viewer for hyperspectral cameras, 2560 pixels / 1680 bands

